



# INTERCONEXIÓN DE SISTEMAS DE POTENCIA USANDO NUEVOS SISTEMAS HVDC – VSC

Ing. Braulio Chuco

Perú



25 a 27 noviembre, 2009



# ***Interconexión de Sistemas de Potencia Usando nuevos Sistemas HVDC – VSC***

***B. Chuco, E. H. Watanabe***

***Centro de Investigaciones Eléctricas – Electrónicas del Perú  
COPPE/UFRJ***



**25 a 27 noviembre, 2009**



# INTRODUÇÃO

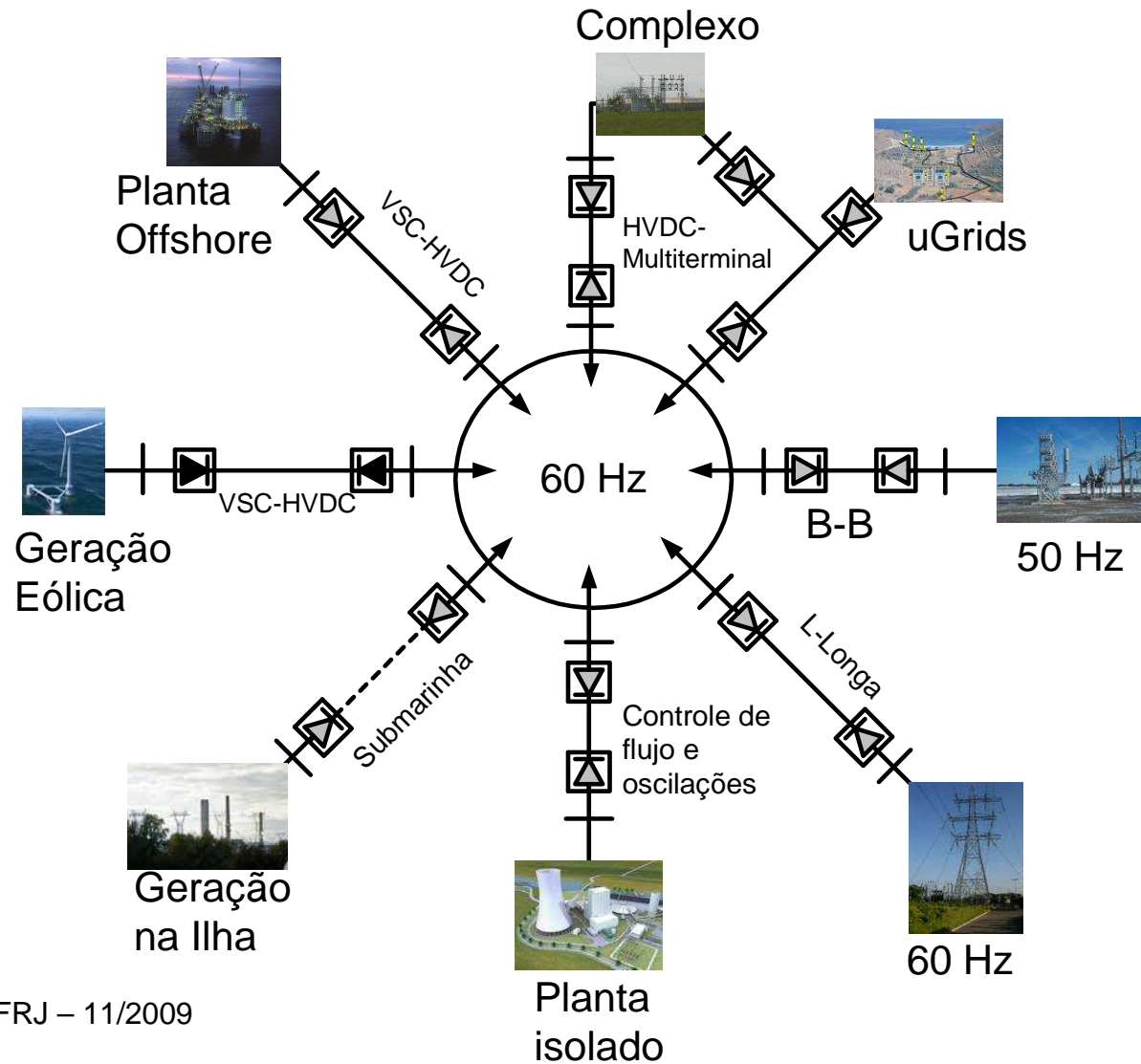



# EVOLUÇÃO DE LOS SISTEMAS HVDC

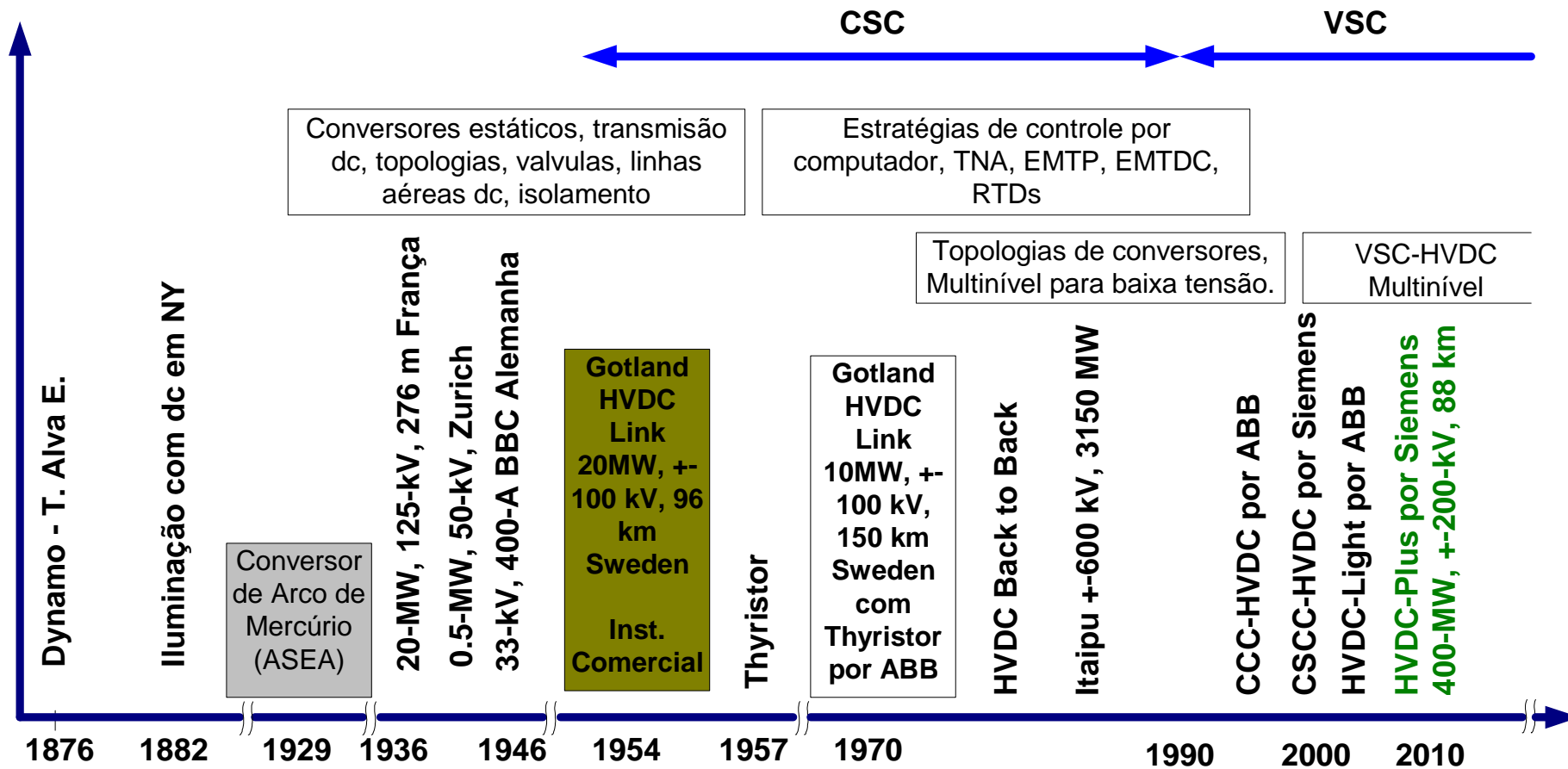



# EVOLUÇÃO DE LOS SISTEMAS HVDC

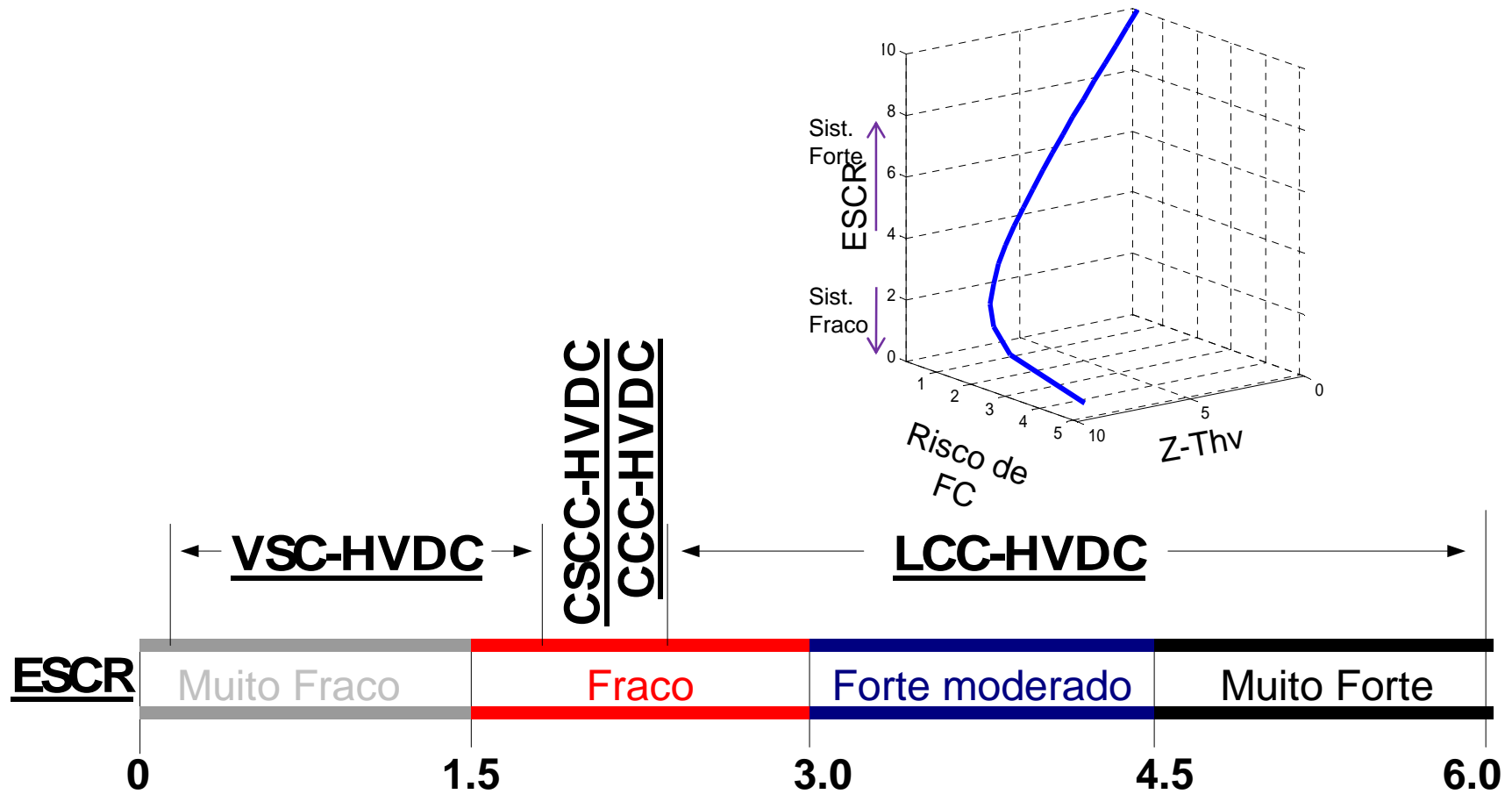



# EVOLUCIÓN DE LOS SISTEMAS HVDC

## LCC-HVDC

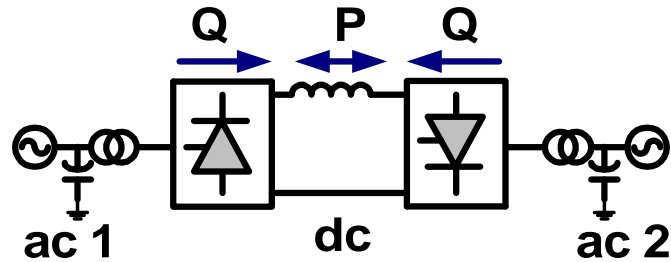

## CCC-HVDC

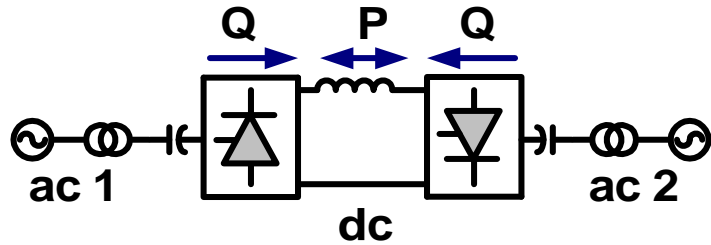

## CSCC-HVDC

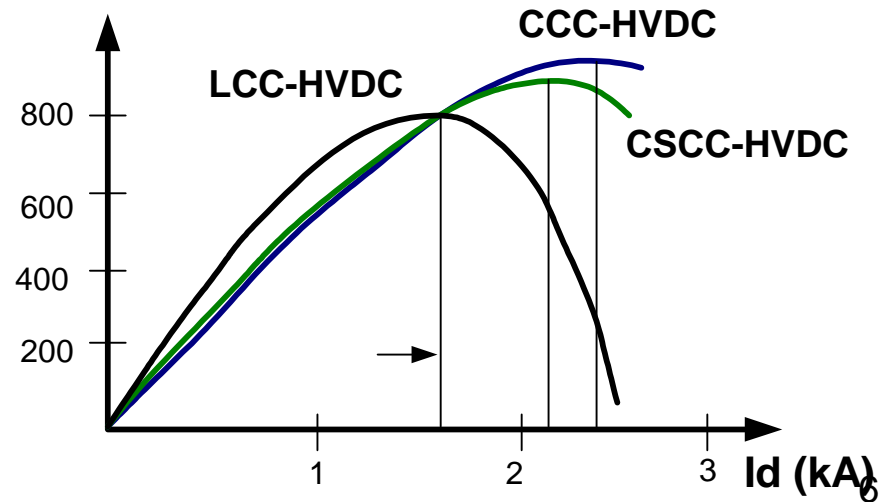
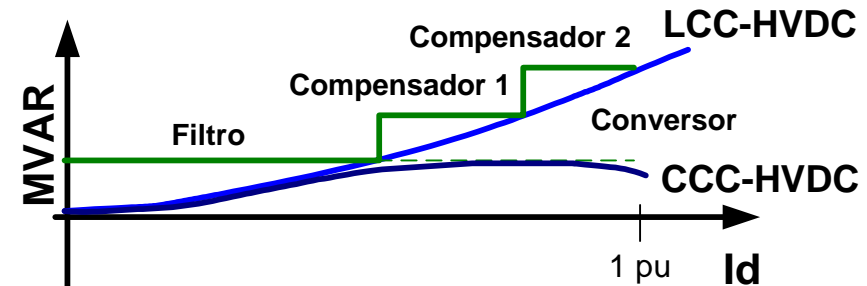
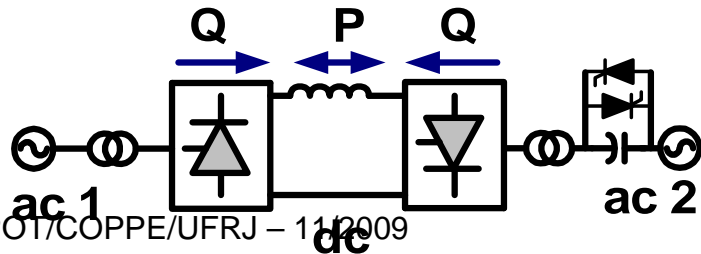



## VSC-HVDC

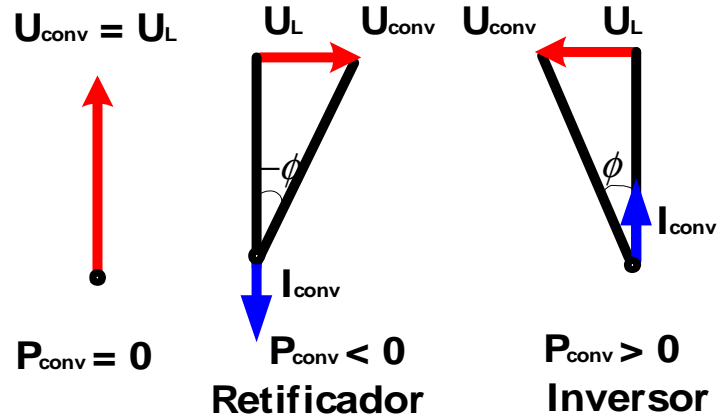
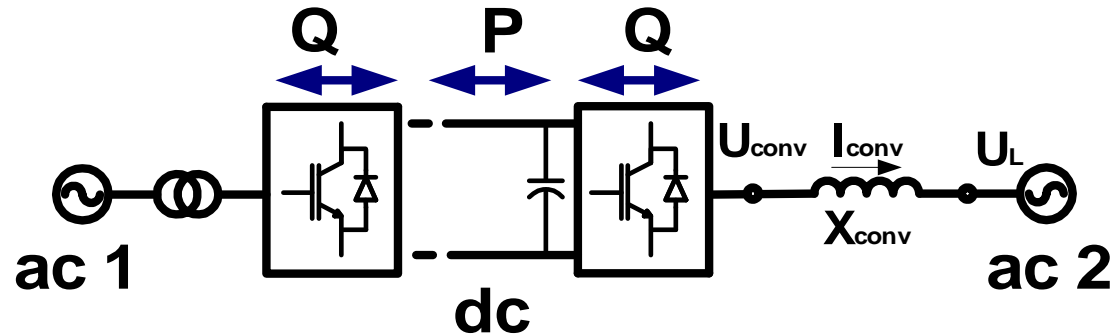

### Controle de Potência Ativa

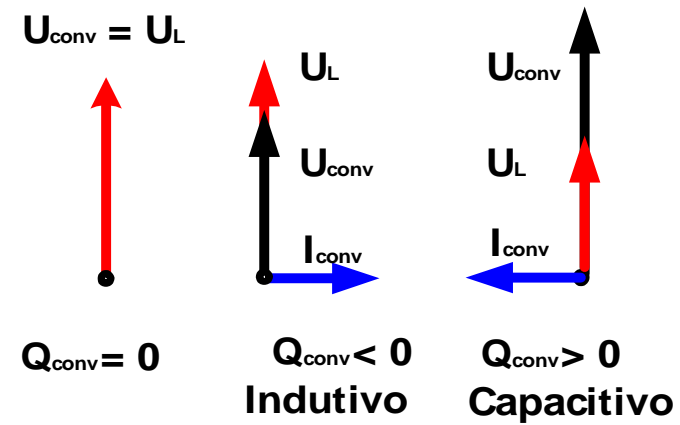

### Controle de Potência Reativa



## VSC-HVDC

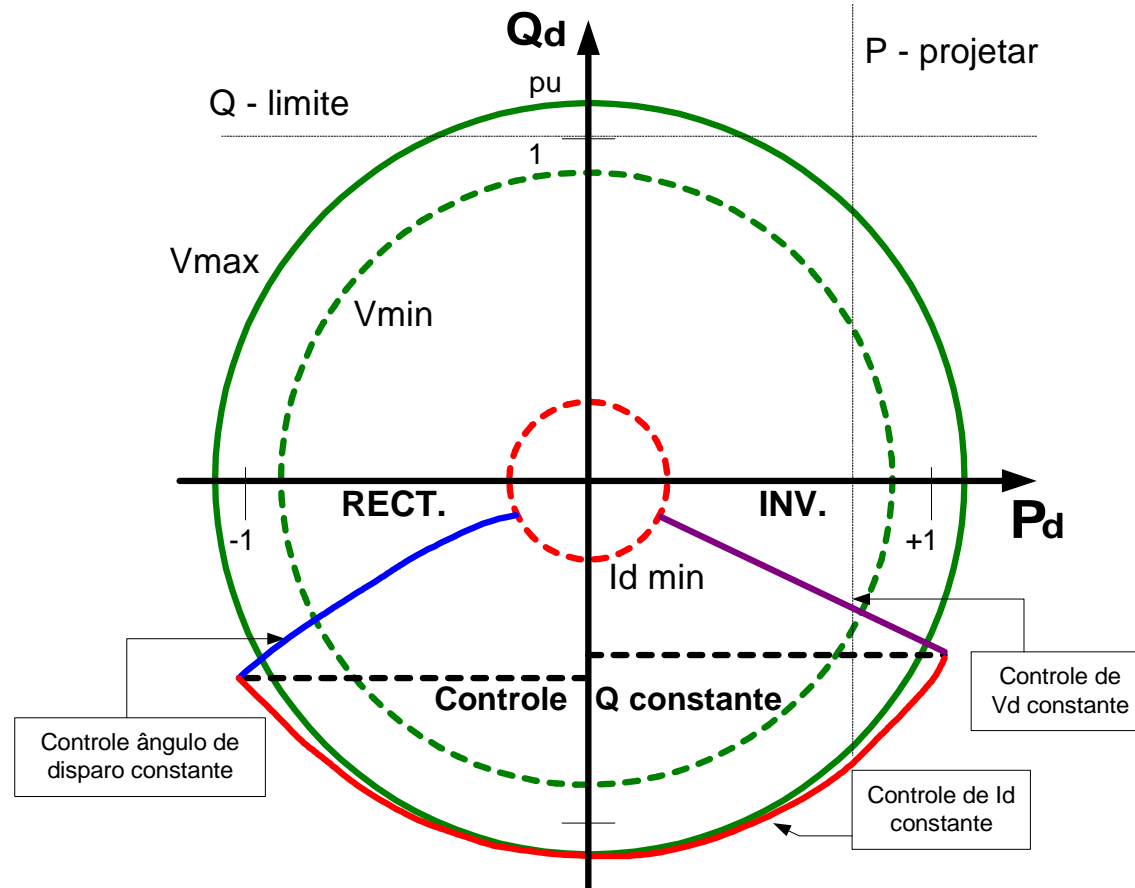

*Región de trabajo del LCC-HVDC y VSC-HVDC*



# CONVERSORES MULTINÍVEL

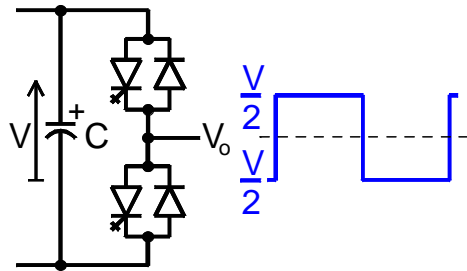

2 - Níveis

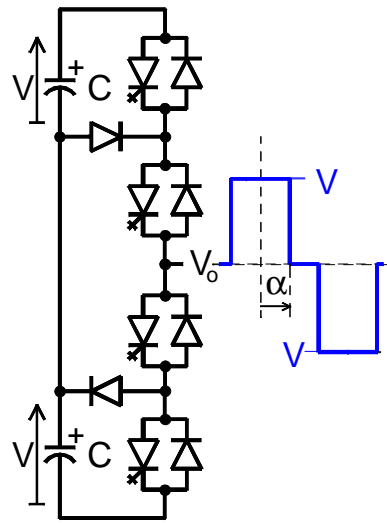

3 - Níveis

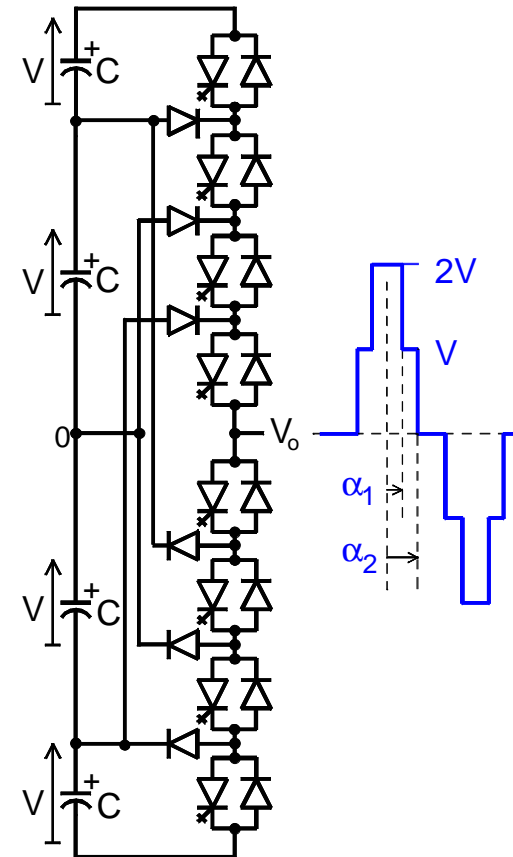

5 - Níveis



## CONVERSORES MULTINÍVEL

**Tipo DIODE – CLAMPED** (NPC and up with DC-Link capacitors)

**Tipo CAPACITOR – CLAMPED**(with flying capacitors and DC Link capacitors)

**Tipo CASCADE H – BRIDGE** (with separate DC-source, without common DC-Link)

**Tipo MODULAR MULTILEVEL CONVERTER** (without separate DC-Sources, with common DC-Link, but without DC-Link capacitors)

**OBJETIVO: Conversor fuente de tensión de potencia con contenido armónico MÍNIMO**

**Puede ser sin transformador!**



# CONVERSORES MULTINÍVEL

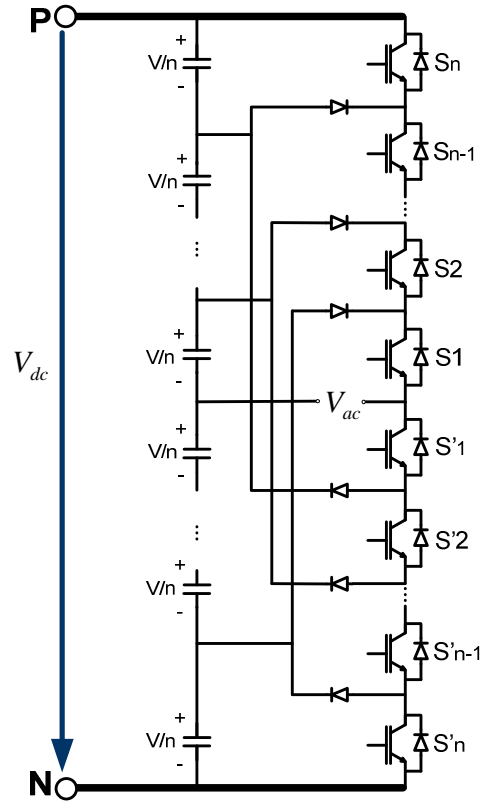

*Tipo: Diode clamped Bridge*

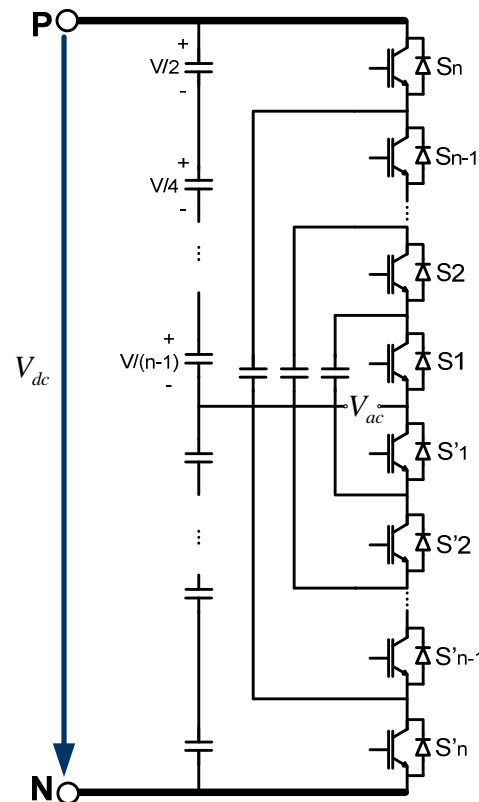

*Tipo: Capacitor clamped*

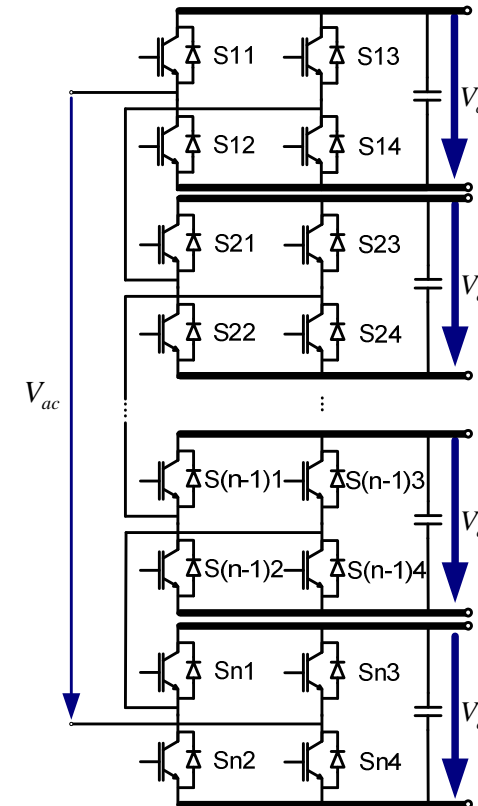

*Tipo: Cascade H-*



# CONVERSORES MULTINIVEL MODULAR CMM

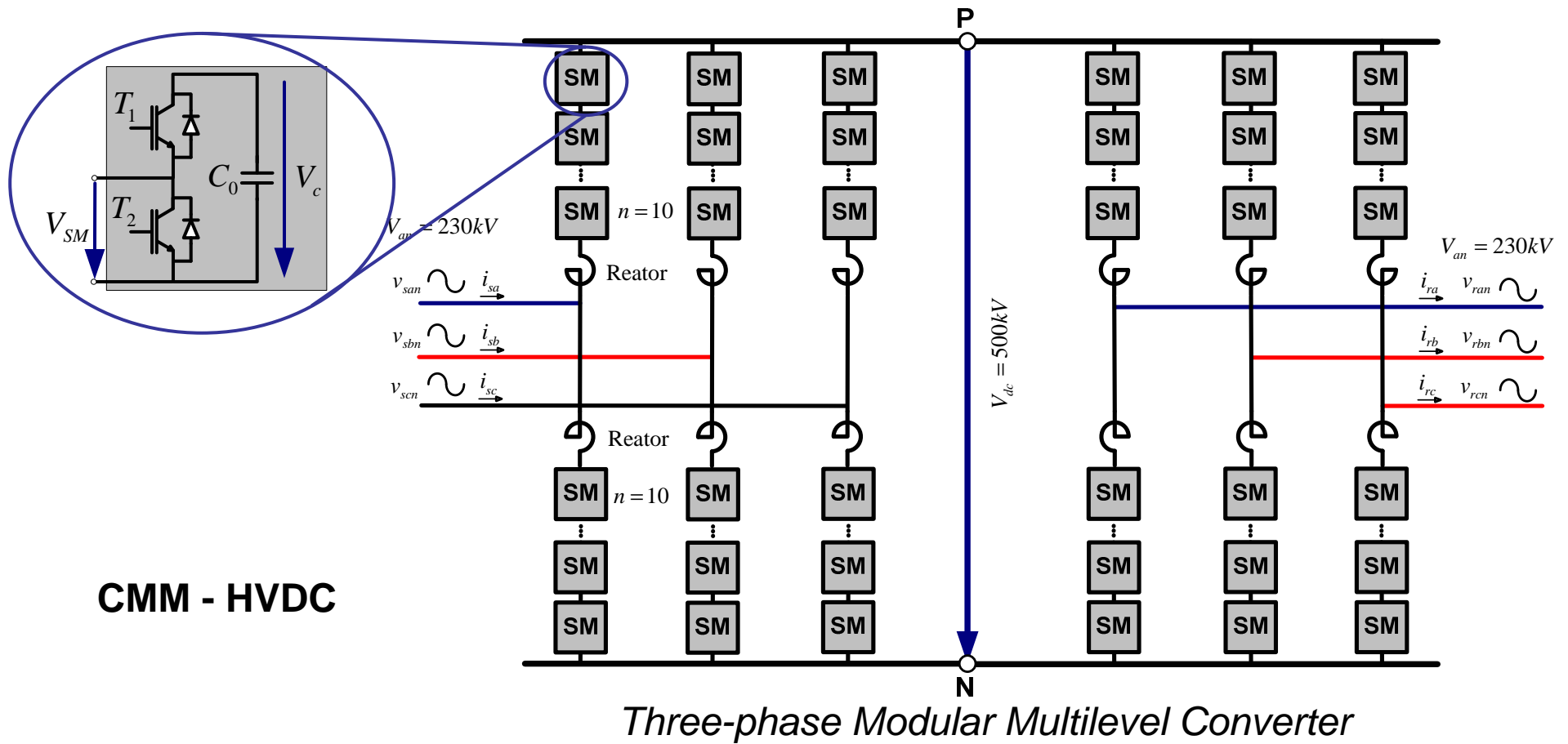



## FUNCIONAMIENTO BÁSICO DEL CMM

**Estado 1**

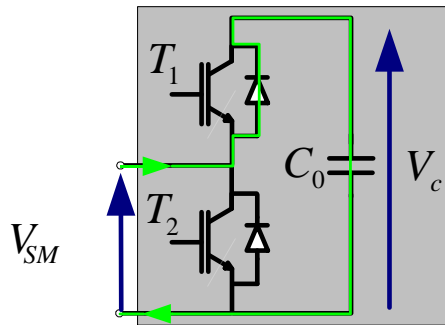

**Estado 2**

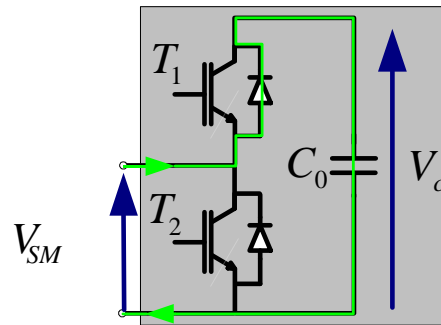

**Estado 3**

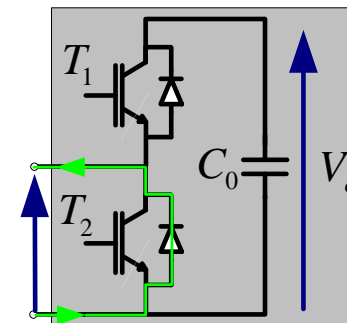
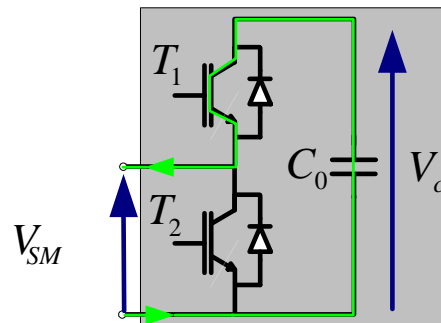
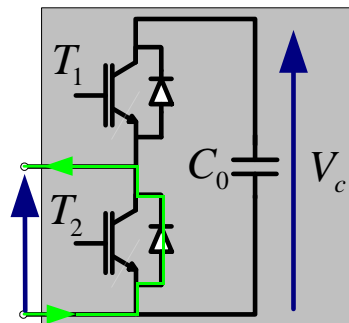
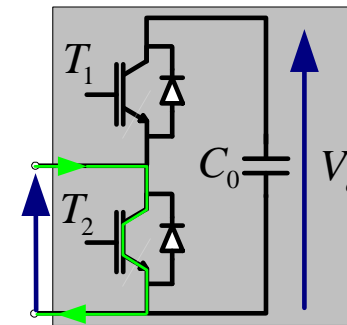

*Estados de operación de los submodulos*

# FUNCIONAMIENTO BÁSICO DEL CMM

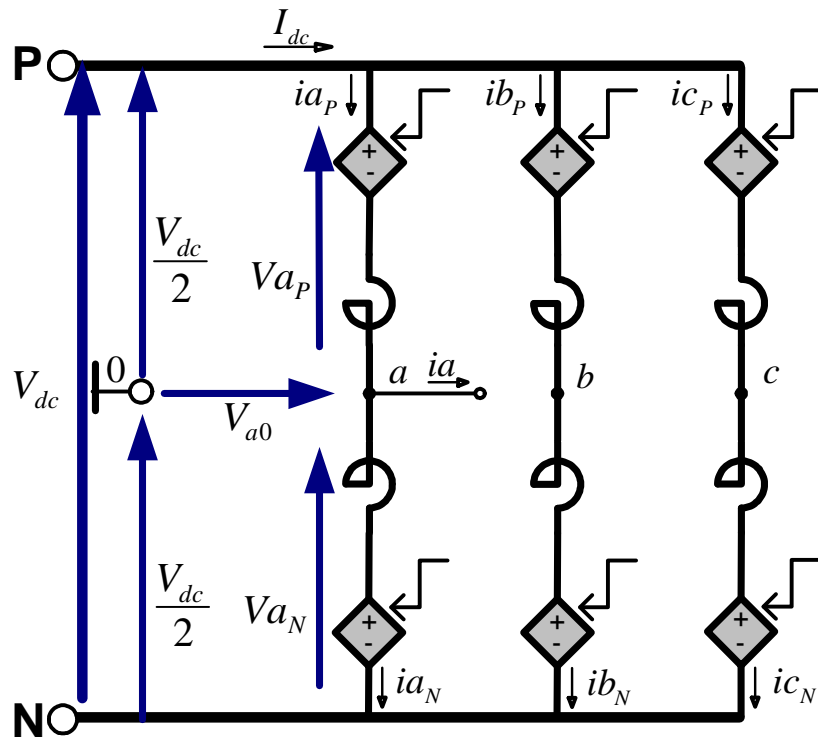

*Circuito Equivalente*

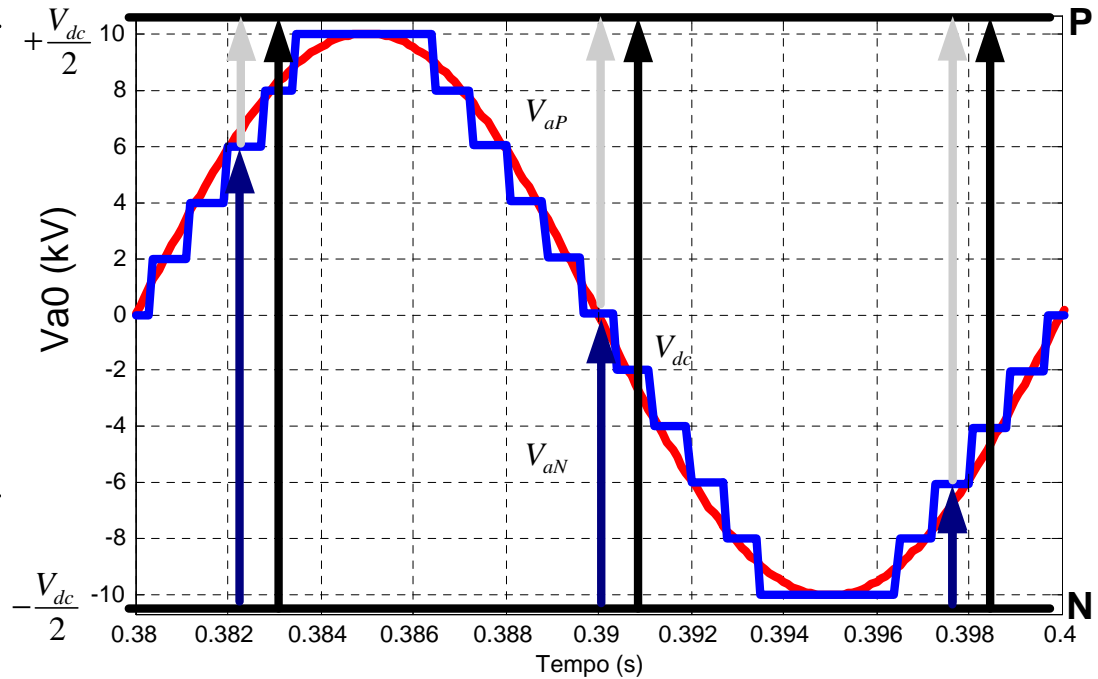

*Tensión de salida*



## FUNCIONAMIENTO BÁSICO DEL CMM

$$V_{a0} = \frac{Va_N}{2} - \frac{Va_P}{2} \quad (1)$$

$$V_{dc} = Va_N + Va_P = Vb_N + Vb_P = Vc_N + Vc_P \quad (2)$$

$$\begin{aligned} i_a &= i_{aP} - i_{aN} \\ i_b &= i_{bP} - i_{bN} \\ i_c &= i_{cP} - i_{cN} \end{aligned} \quad (3)$$

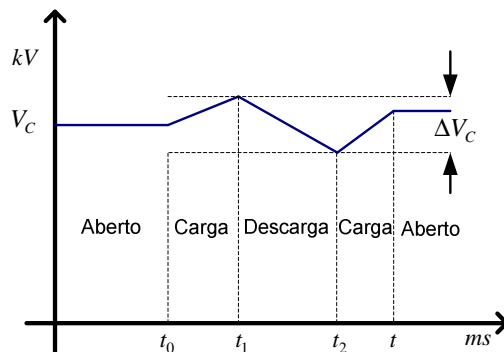

$$V_{dc}(t) + |2V_{a0}(t)| \leq 2nV_C \quad (4)$$

$$\Delta V_C = \frac{1}{C} \int i dt \rightarrow \Delta V_C = \frac{1}{C} i \Delta t \quad (5)$$

$$C_0 = \frac{1}{\Delta V_C} i \Delta t \quad (6)$$



# FUNCIONAMIENTO BÁSICO DEL CMM

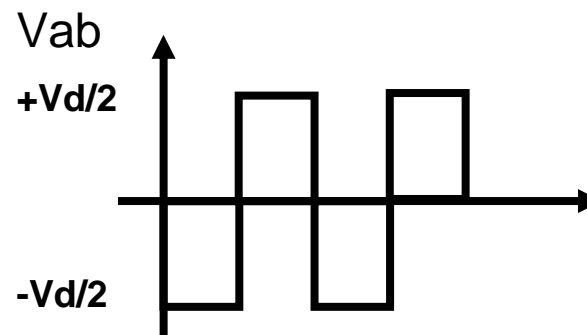
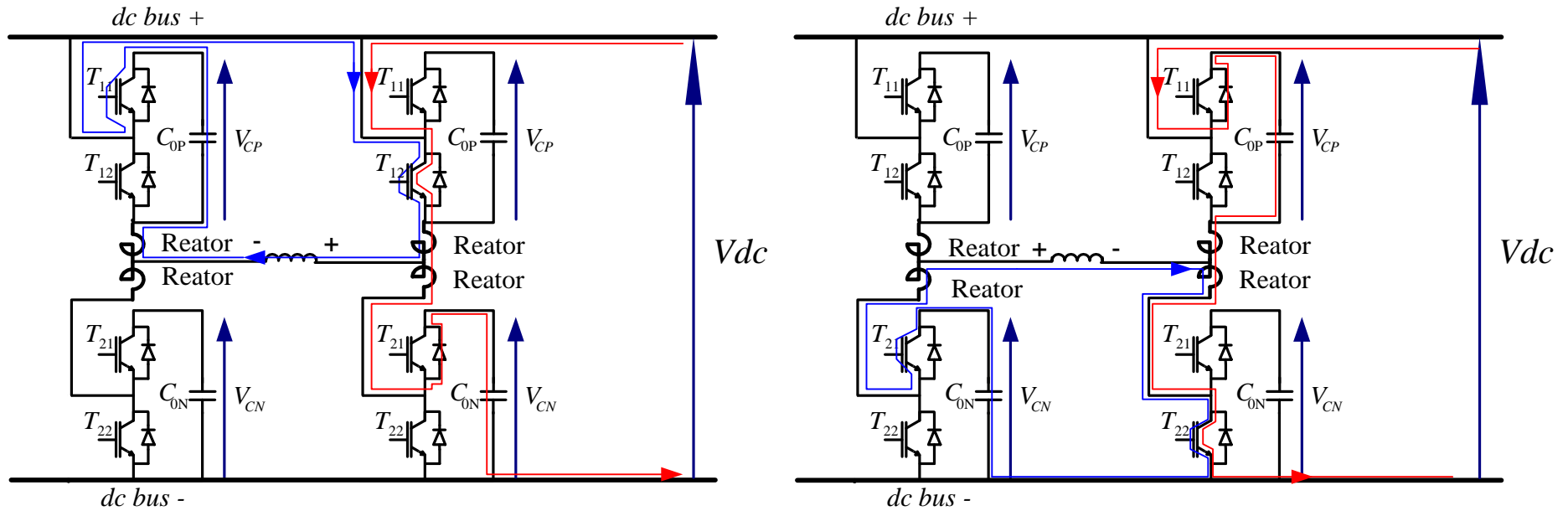



## FUNCIONAMIENTO BÁSICO DEL CMM

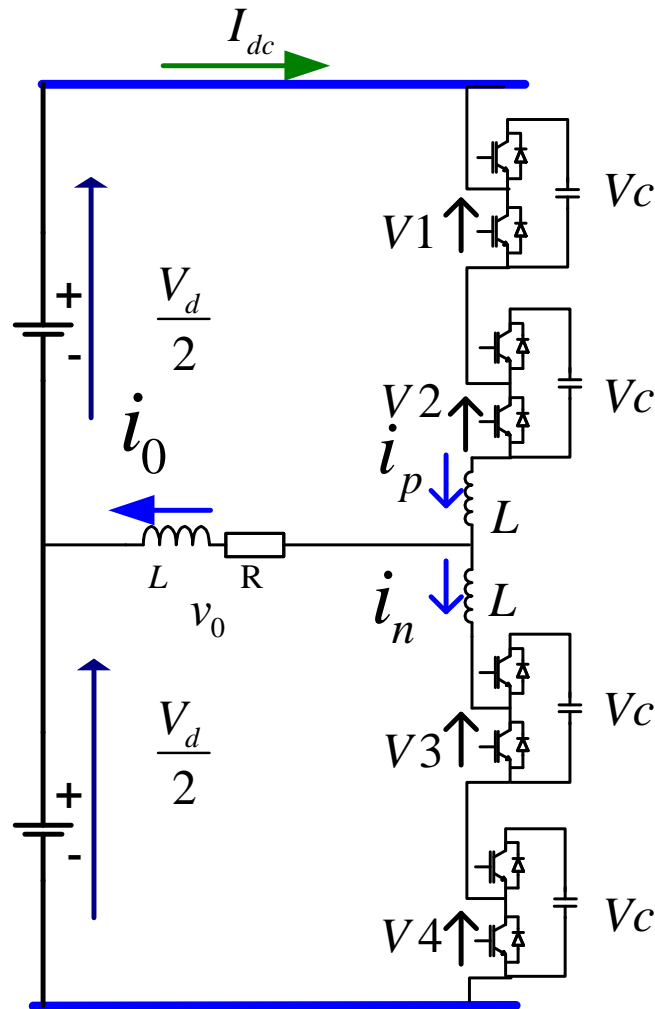

$$V_c = \frac{V_d}{2}$$

$$V_d = \sum_{n=1}^4 V_n + L \frac{d}{dt} (i_p + i_n)$$

$$i_z = i_p - \frac{i_0}{2} = i_n + \frac{i_0}{2}$$

$$i_z = \frac{1}{2} (i_p + i_n)$$



## FUNCIONAMIENTO BÁSICO DEL CMM

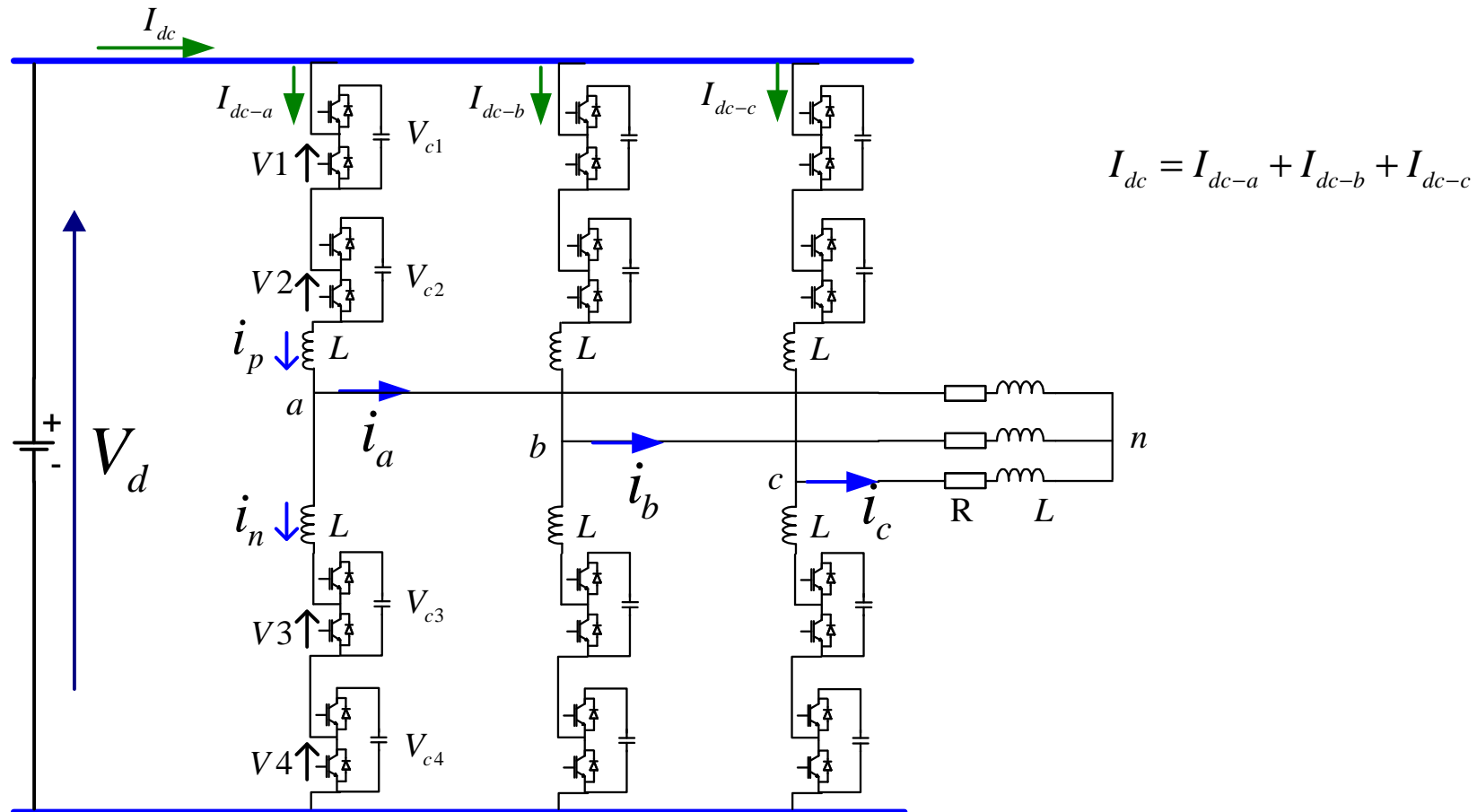



# FUNCIONAMIENTO BÁSICO DEL CMM

## Criterios de operación

1. En régimen permanente, **50% de los Submodulos** de cada pierna opera en **Estado 2**
2. La tensión en el capacitor dada por  $V_c = \frac{V_{dc}}{n/2}$ , siendo **n** el número de submodulos por pierna y por fase
3. Cada Submodulo es bi-direccional en corriente para **todos los Estados**
4. Es necesario la **pré-carga** de los capacitores de todos los Submodulos de forma seqüencial antes de conectar a la red



## RESULTADOS

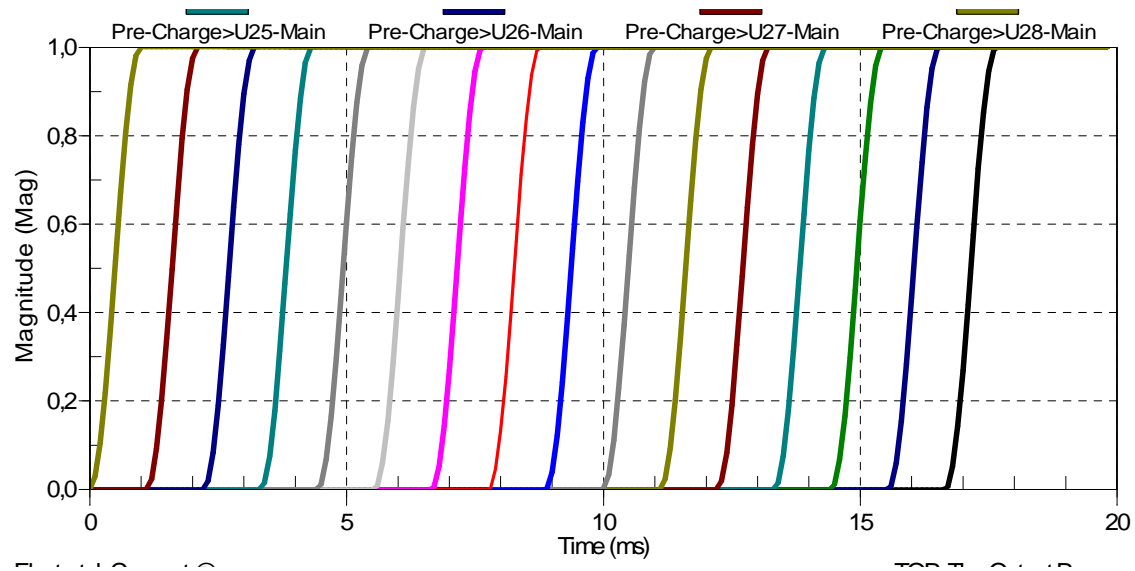

*Carga inicial de los capacitores*



## RESULTADOS

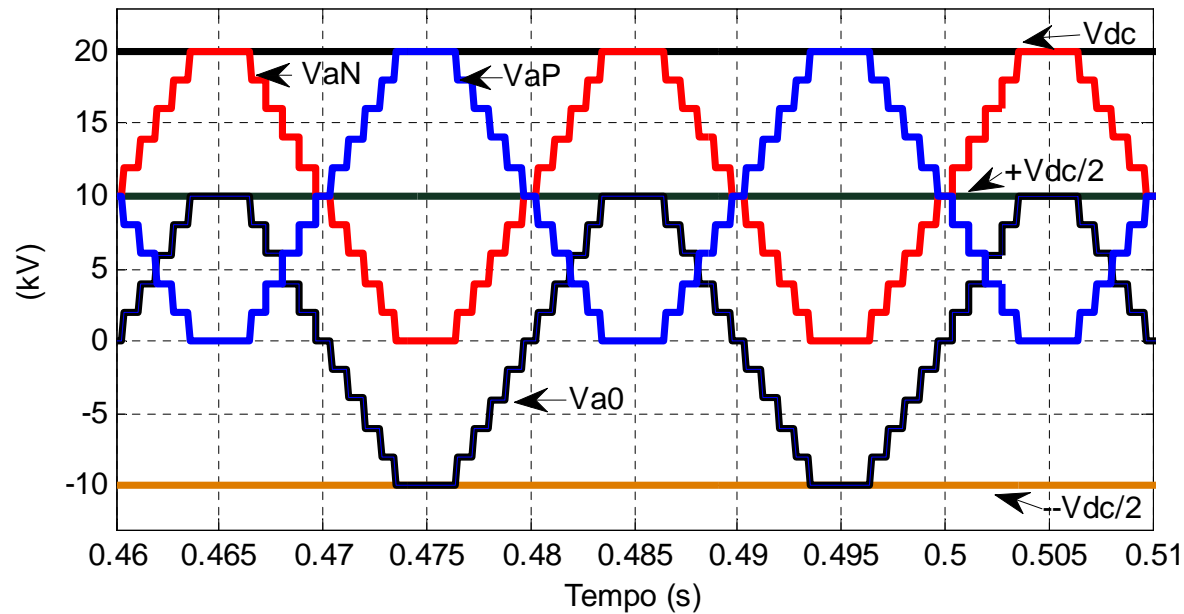

*V<sub>dc</sub>, tensiones en el conversor y tensión en la salida del inversor*



## RESULTADOS

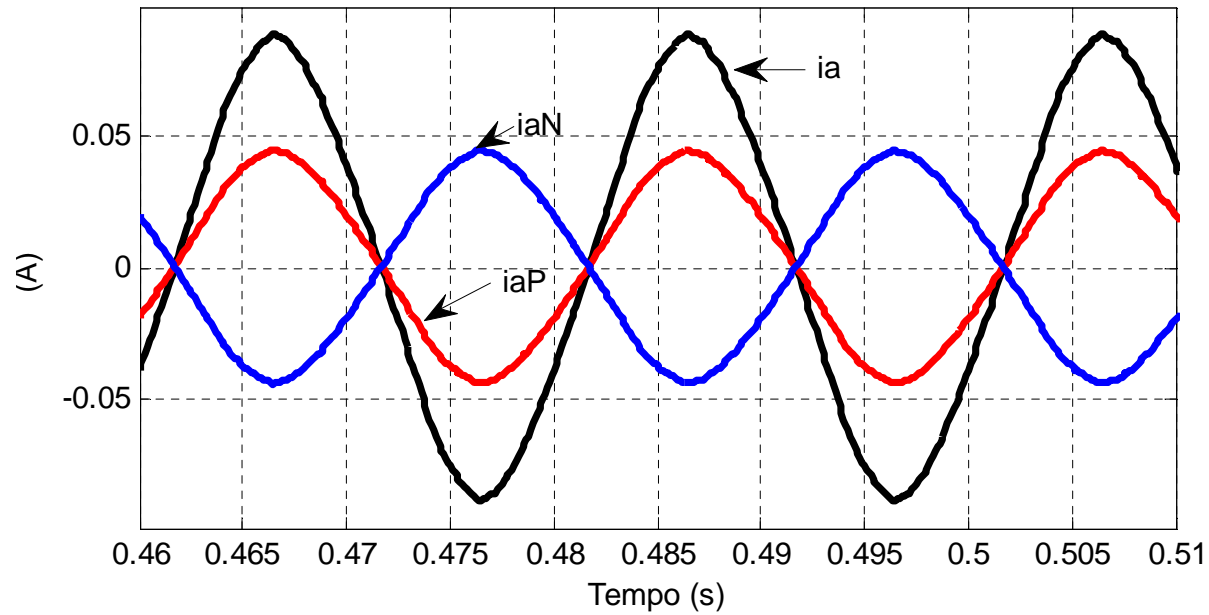

*Corriente en el conversor , corriente en la salida del inversor*



## RESULTADOS

**El sistema de análisis:** los sistema CA es de 230 kV, 50 Hz. Es interligado por un CMM-HVDC de 11 niveles, compuesto por 20 Submódulos por fase, la tensión cc es de 500 kV.

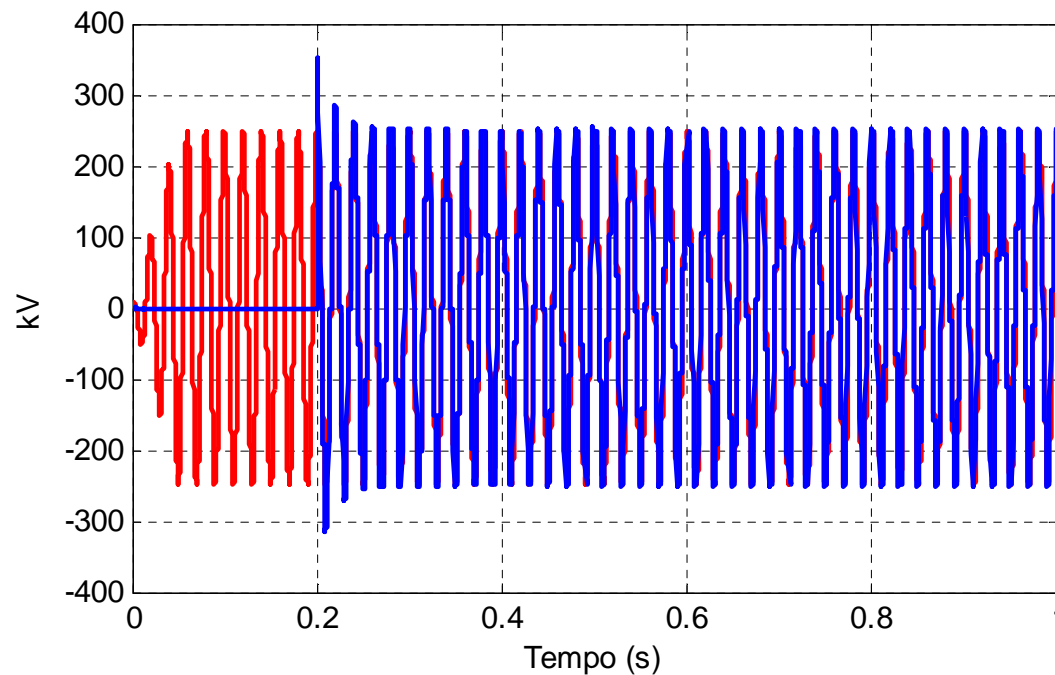

*Inicialización de la tensión en el inversor*



## RESULTADOS

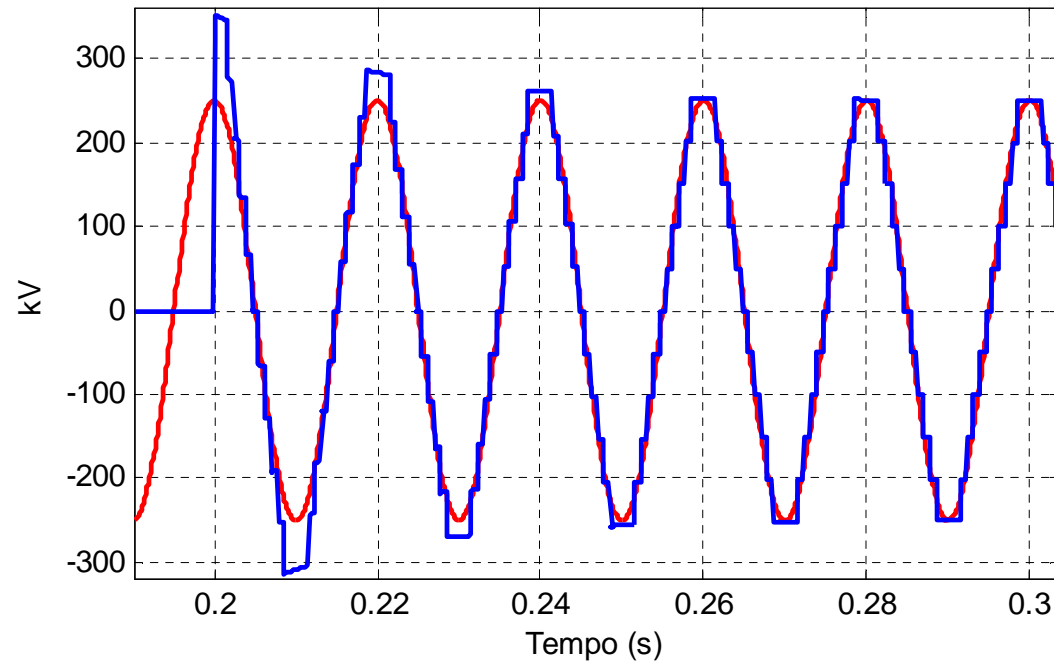

*Inicialización de la tensión en el inversor*



## RESULTADOS

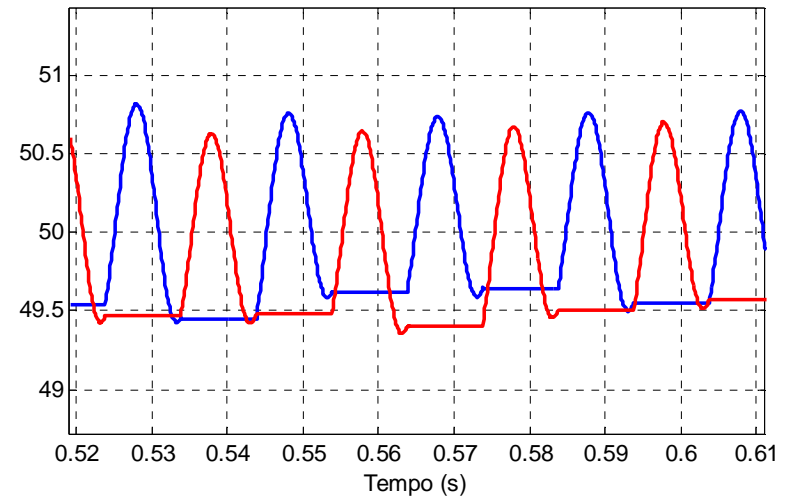
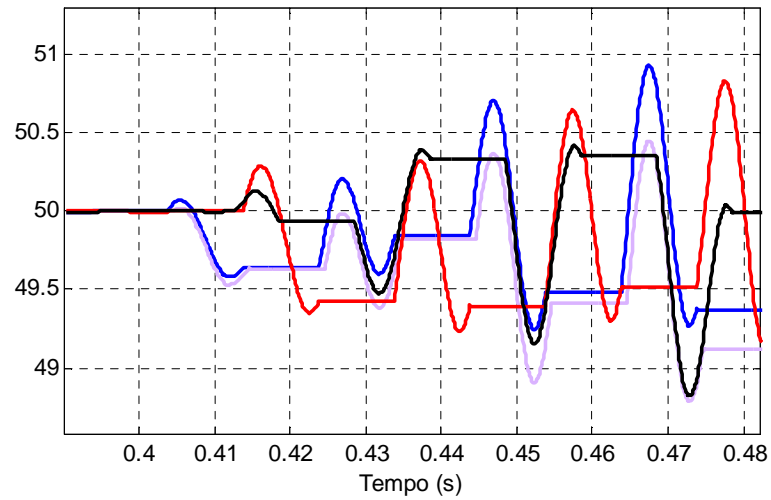

*Tensão em los capacitores*



## RESULTADOS

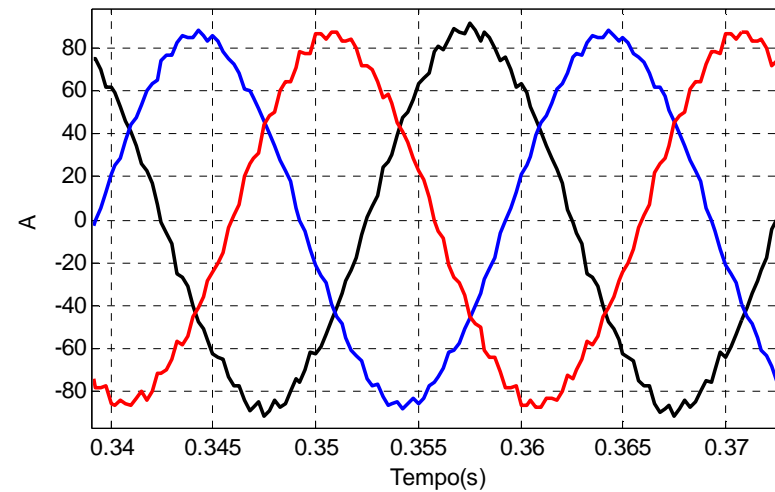
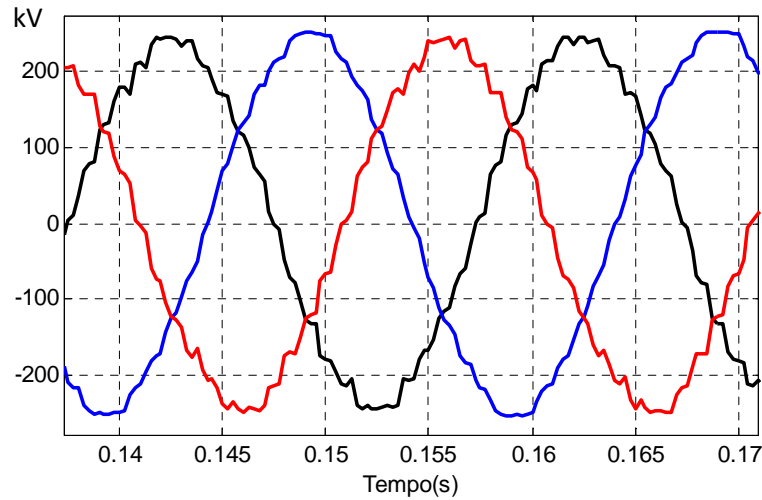

*Tensão y corriente en el inversor*



## RESULTADOS

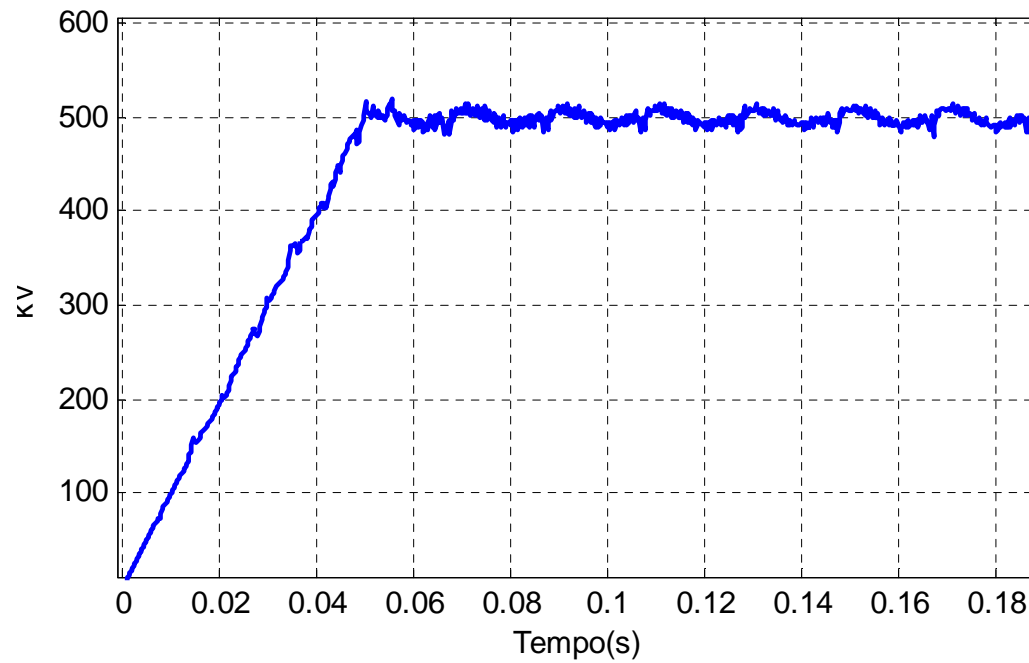

*Tensión cc*



## CONCLUSIONES

- ▶ Reduce pérdidas y extiende la vida útil de los IGBTs
- ▶ Reduce armónicos
- ▶ Modularidad
- ▶ Impacto positivo en la confiabilidad
- ▶ Es necesario controlar la tensión en cada capacitor para controlar el flujo de potencia activa y reactiva.



**MUCHAS GRACIAS**

[bchuco@cieep.org](mailto:bchuco@cieep.org), [watanabe@coe.ufrj.br](mailto:watanabe@coe.ufrj.br)